

FarmBridge™ Single Axle Weigher

Simple, efficient truck weighing



Accurate on-the move weighing

- Simple to use
- Automatic Operation
- Dynamic and/or static weighing
- Heavy Duty
- Maintenance Free
- Versatile in use
- Any length vehicle
- 24 month warranty

Introduction

The FarmBridge™ Axle Weigher provides accurate weighing for any type of vehicle regardless of length or number of axles. As vehicle moves slowly across the platform an electronic control records and logs the weight of each axle.

The heavy-duty construction has been built to work in harsh environments and is particularly suited where high volumes of traffic are being weighed.

The platform has been specifically designed to weigh all axle combinations including single, tandem and tri-axle combinations. The system efficiently and accurately records each axle individually and provides total weights once the vehicle is fully weighed. Close coupled axles with spring or air suspension are no problem and single axle weights up to 30,000kg are acceptable.

Dynamic Weighing

In-motion (dynamic) weighing is an established feature of axle weighing and our system was originally developed in the early 1980s. It formed the basis of the FarmBridge™ Single Axle Weighing system, which today utilises state-of-the-art electronics and software to provide the highest accuracy for weighing individual axles.

Operation

As the vehicle moves over the FarmBridge™ in low gear the axles are automatically recorded in motion. The electronics records the actual weight of each axle and immediately displays the weight.

Automatic operation of the FarmBridge™ allows the driver to weigh without leaving the vehicle or the need for a specialist operator to be present. The unique automatic zeroing system ensures the correct weight is achieved for each axle and zero adjustments between weighings are not required.



ABN: 50 119 216 152

49 Fraser Street
Herne Hill Victoria 3218
Tel: 03 5229 0007
Fax: 03 5221 0107

Email: info@farmweigh.com.au

www.farmweigh.com.au

Specialists in Weighing Solutions
for agriculture, mining & industrial

Installation & Maintenance

- Easy to install & maintain
- Full supervision & assistance with installation & commissioning
- Turn-key installation option
- Comprehensive installation, operation and maintenance manual
- 24 hour 7 day support hotline

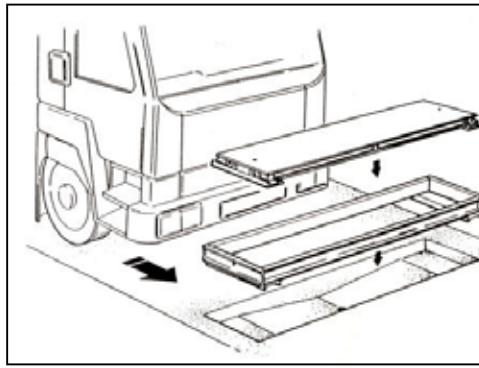

Options & Accessories



Red/Green Traffic Light; required for static weighing to ensure the speed of the vehicle is correct and provides visual indication to the driver that the weight has been successfully recorded.

When used as a static weigher a single light is all that is required to provide visual indication that the weight has been recorded.

Large Character Remote Display; provides the recorded weight of each axle as the weighing is taking place. This provides the driver the information to confirm that the load conforms to legal load limits.



Specifications

Maximum axle weight	30,000kg – 30 tonnes
Maximum gross weight of vehicle	
Static Weighing accuracy	+/- 20kg
Dynamic Weighing accuracy	+/- 50kg per axle or +/- 1% (whichever is lesser)
Indicator resolution	10kg increments
Vehicle speed requirement (Dynamic Weighing)	Up to 10km per hr max (recommended 3 to 5km per hr)
Power requirements	110/220 v ac; 50/60 hz
Platform dimensions	3000mm x 700mm x 200mm
Platform type	Welded construction, epoxy coated mild steel
Loadcells	9000kg hermetically sealed, stainless steel (IP 68)

Your local FarmWeigh dealer is:



ABN: 50 119 216 152

49 Fraser Street
Herne Hill Victoria 3218
Tel: 03 5229 0007
Fax: 03 5221 0107

Email: info@farmweigh.com.au



www.farmweigh.com.au

**Specialists in Weighing Solutions
for agriculture, mining & industrial**